



PURGIT®
 3100 Edloe St. Suite 350
 Houston, TX 77027
 www.purgit.com

713-201-7517 . TEL
 888-621-3132 . TOLL FREE
 713-621-3112 . FAX
 sales@purgit.com

PURGIT REFRIGERATED VAPOR RECOVERY SYSTEM

- No Source of Ignition
- 100% Control Efficiency
- Zero Emissions From Tank
- Zero NOx



Closed Loop Tank Degassing Service

PURGIT builds and operates refrigerated vapor recovery units. The PURGIT units recover hydrocarbon vapor 2-3 times faster than thermal oxidizers without reportable emissions and without a source of ignition. This equates to a faster and safer tank turnaround event. PURGIT units simply condense the VOC out of the vapor stream. There is no combustion in the process which allows this one system to be used for a larger number of tank products than any other mobile system. In addition, the PURGIT unit can degas an inert tank (low or zero O2) and keep it inert throughout the operation. The PURGIT service is much safer, faster and more effective than any other vapor control system available.

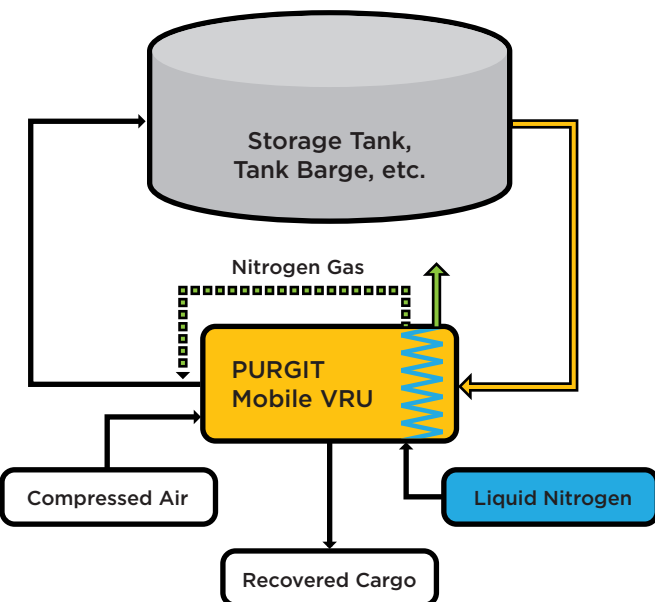
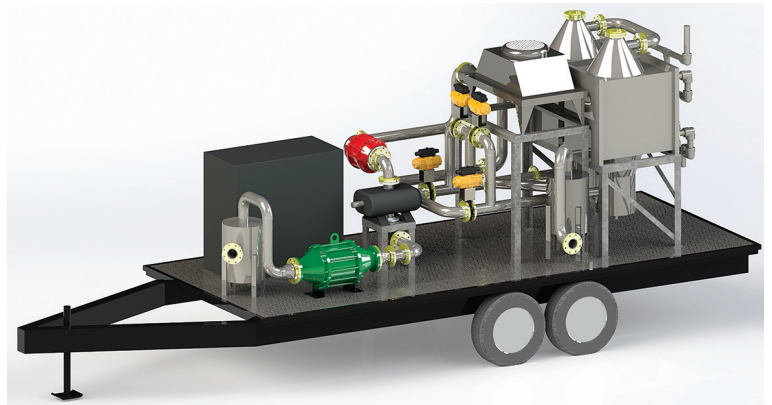

Some of the many products recovered include: Gasoline, crude oil, benzene, butadiene, butyl acrylate, EDC, naphtha, chloroform, isoprene, butane, perchloroethylene, methylene chloride, and cyclohexane.

PURGIT's 'closed loop' provides the necessary mixing in the tank vapor space to prevent dead areas. Thermal oxidizers cannot do this. Without proper mixing it is not possible to get a representative sample of the vapor to confirm compliance with state or facility specifications.

